

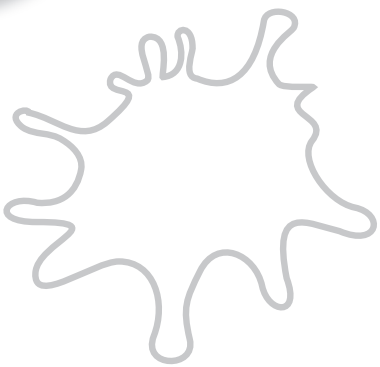

1



2



3

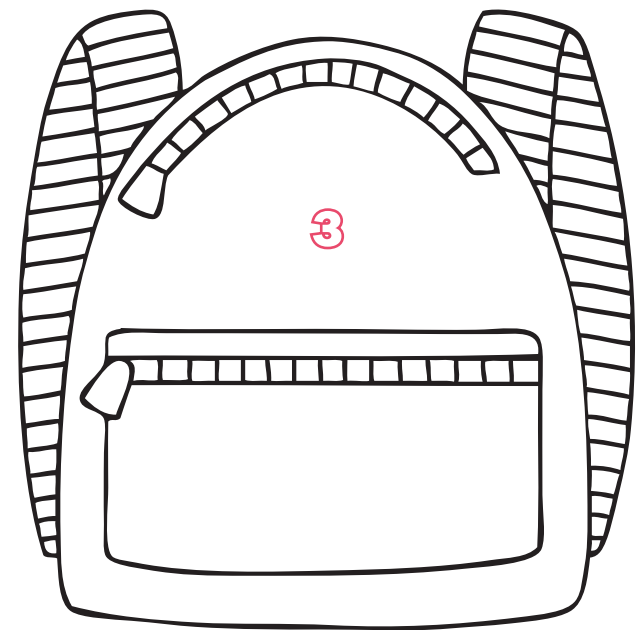
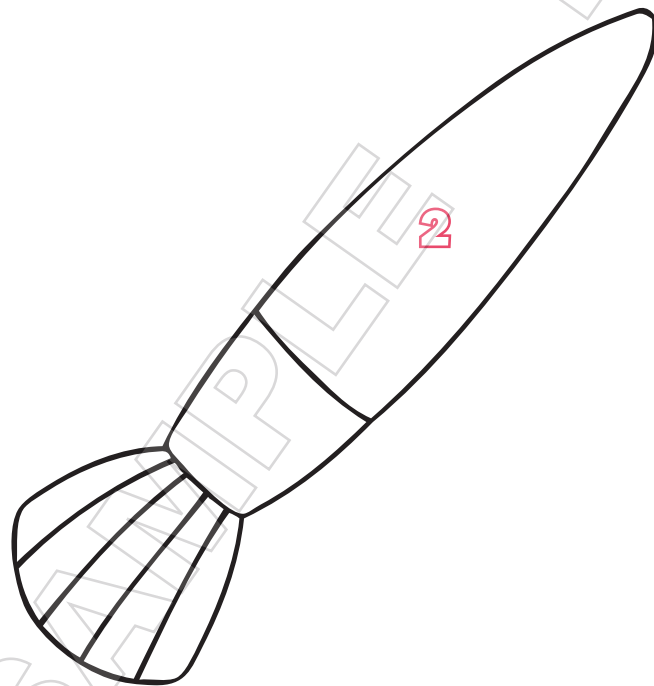
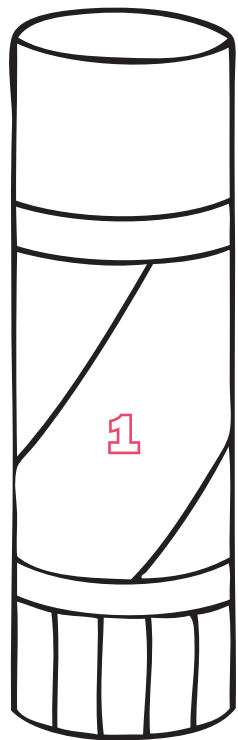
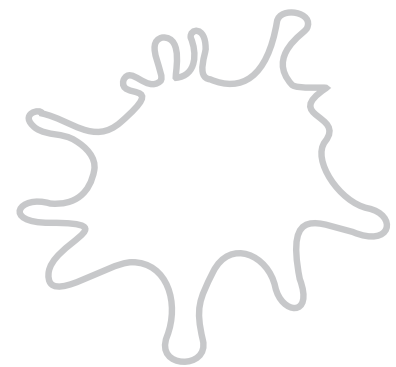

Point and say. Color the key. Color by number.
Key Language Review: backpack, glue stick, paintbrush



Lesson 2

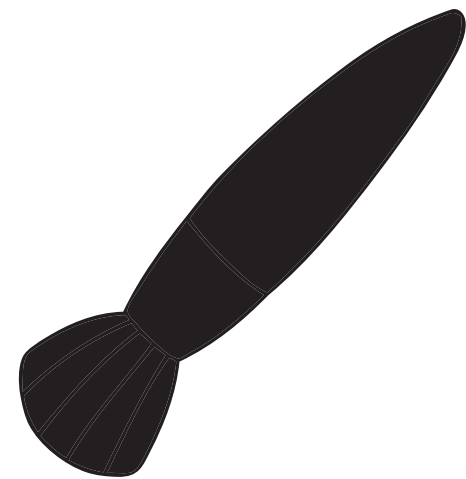
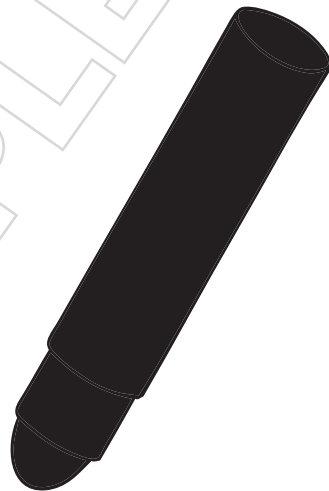
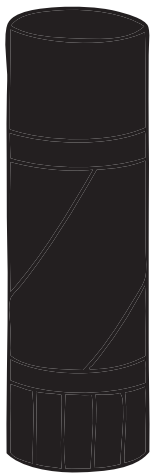
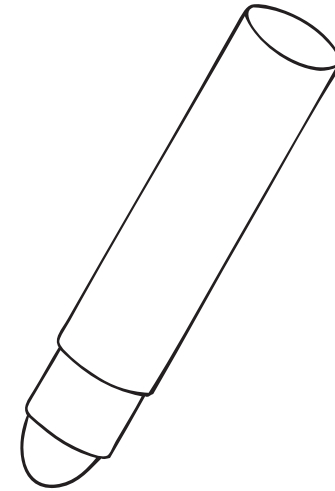
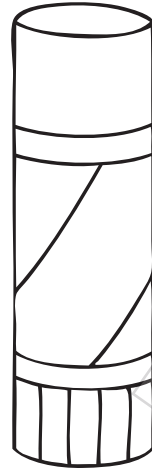
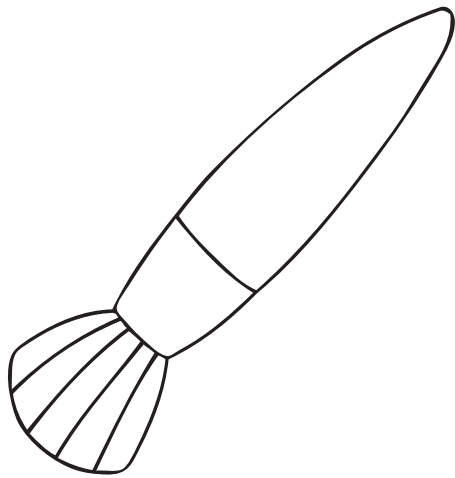

Connect the school objects to the shadows. Point and say: *Can I have a (paintbrush), please? Here you are.*
Key Language Review: glue stick, marker, paintbrush, Can I have a (paintbrush), please? Here you are.

Storysong

Lesson 3

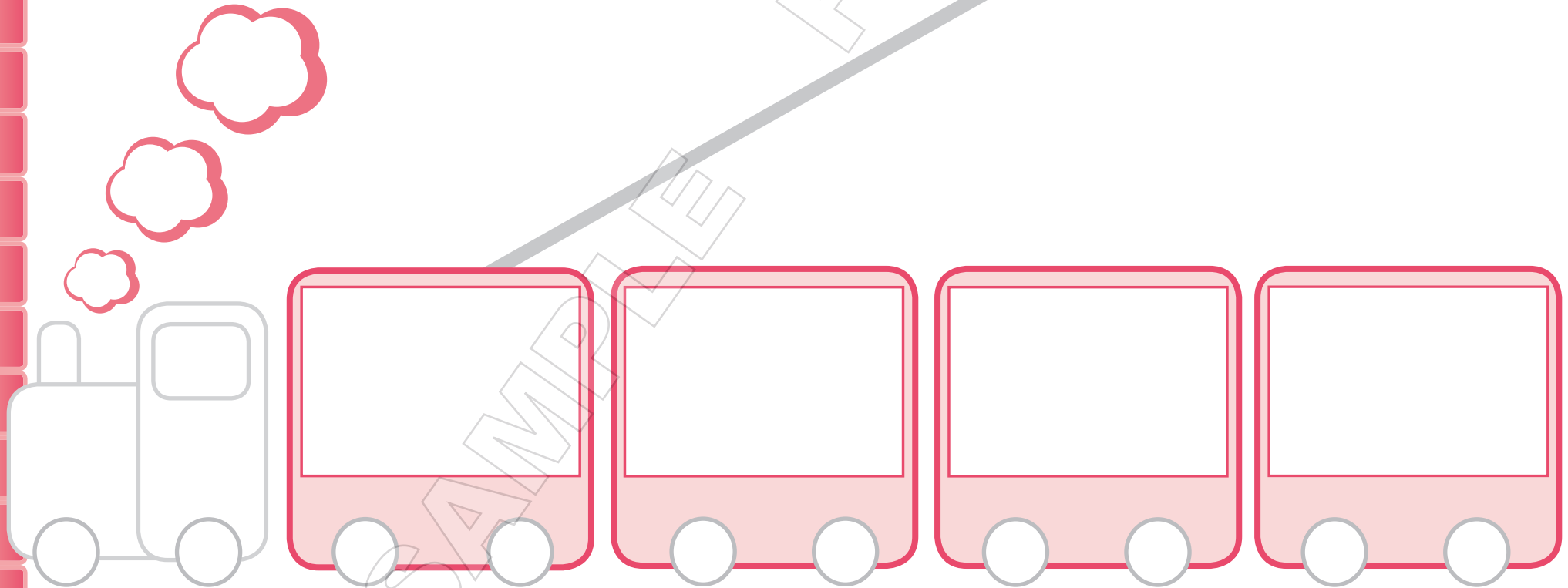

Connect the pictures to the train to complete the story. Paste circles on the wheels in a black / red pattern.
Key Language Review: circle, black, red



Lesson 4

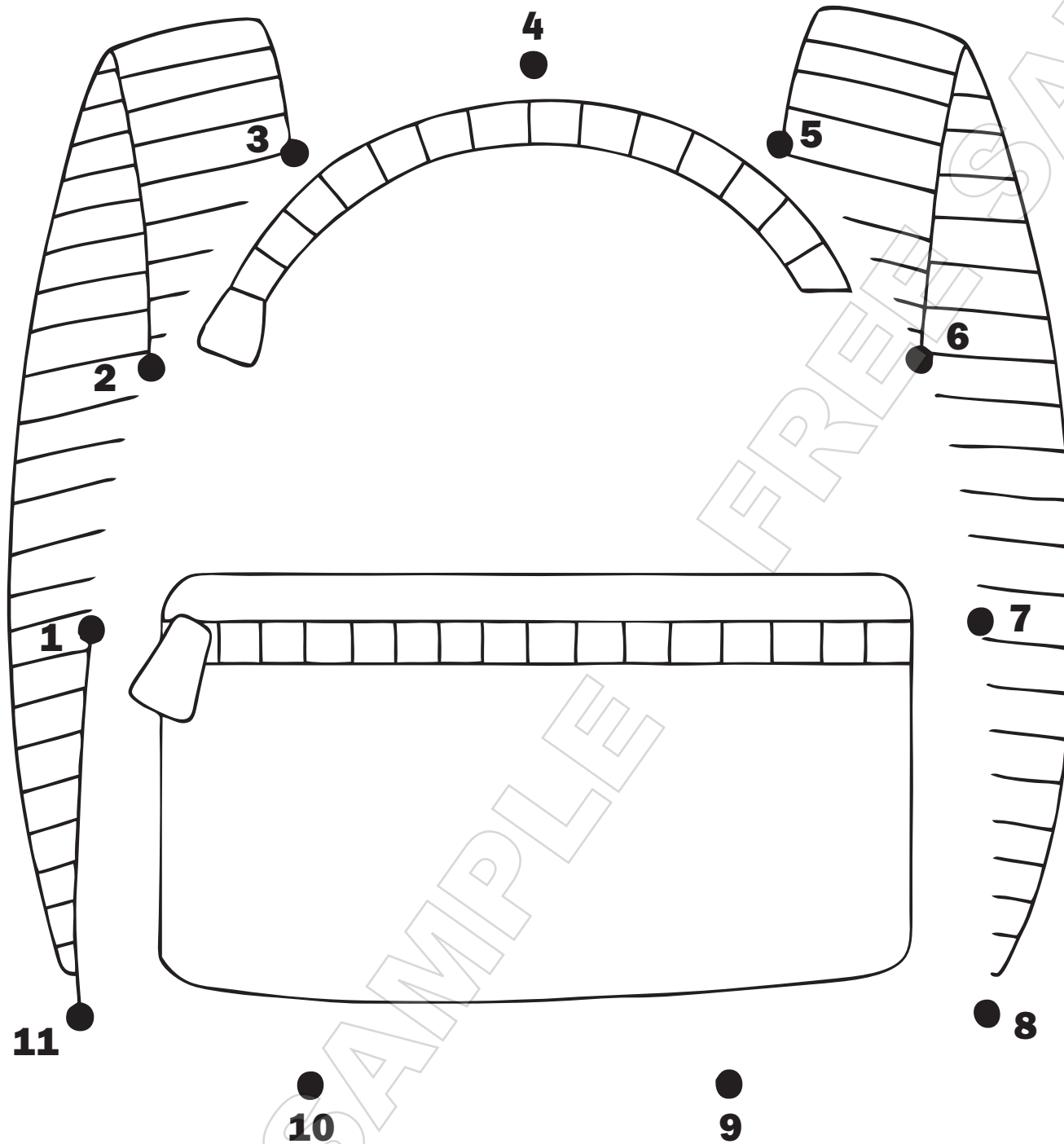

Count and connect the dots to complete the school object. Point and say the school object. Decorate the backpack.
Key Language Review: backpack, 1-11



Lesson 5

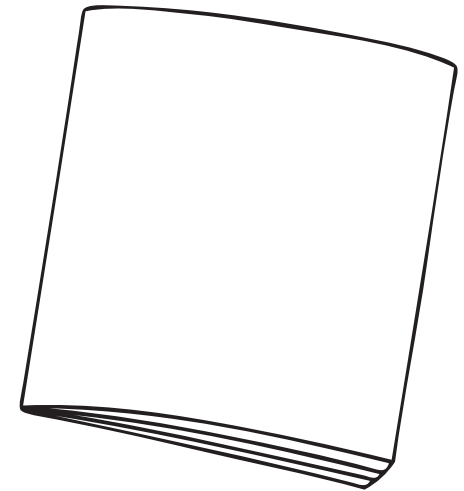
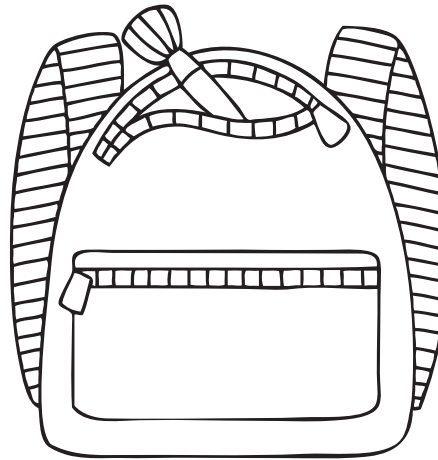
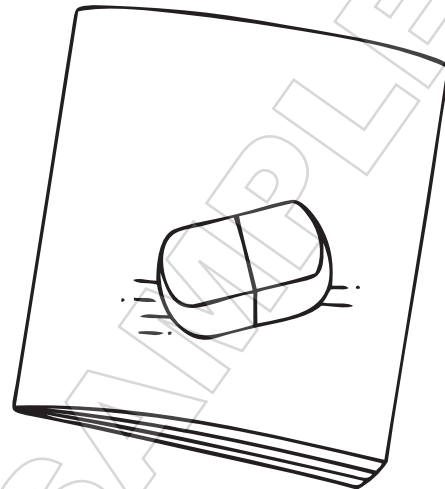
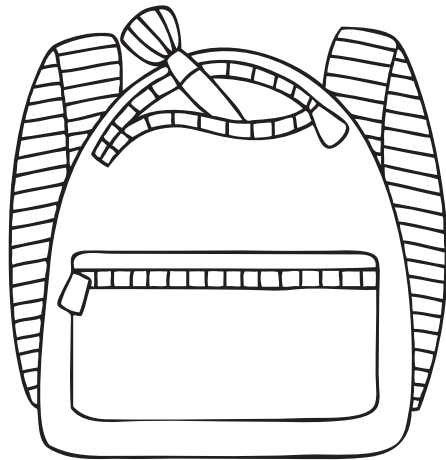
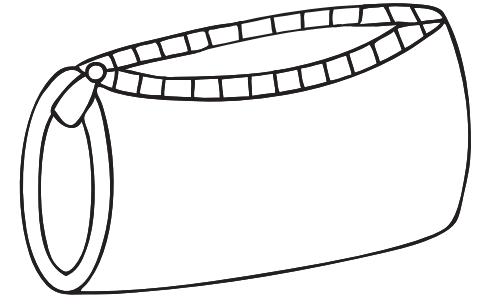
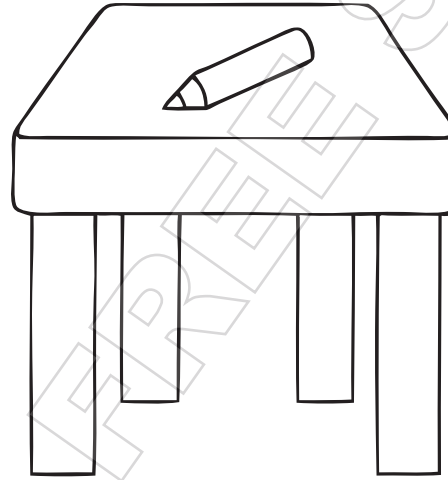
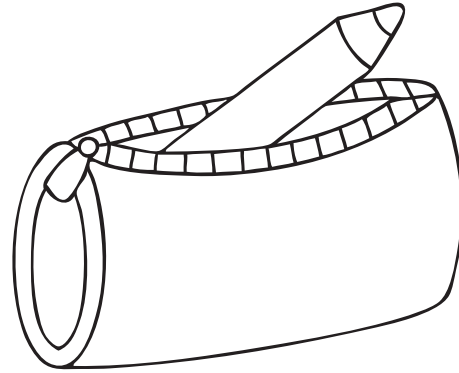
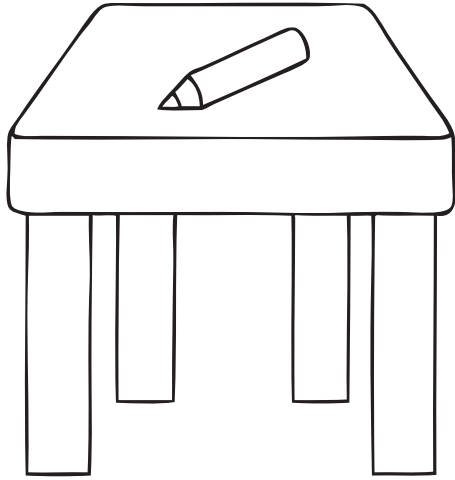

Complete the pictures with the missing school objects. Point and say: *Where's the (pencil)? It's (in) the (pencil case).*
Key Language Review: backpack, book, eraser, paintbrush, pencil, pencil case, table, The (pencil) is (in) the (pencil case).



Lesson 6

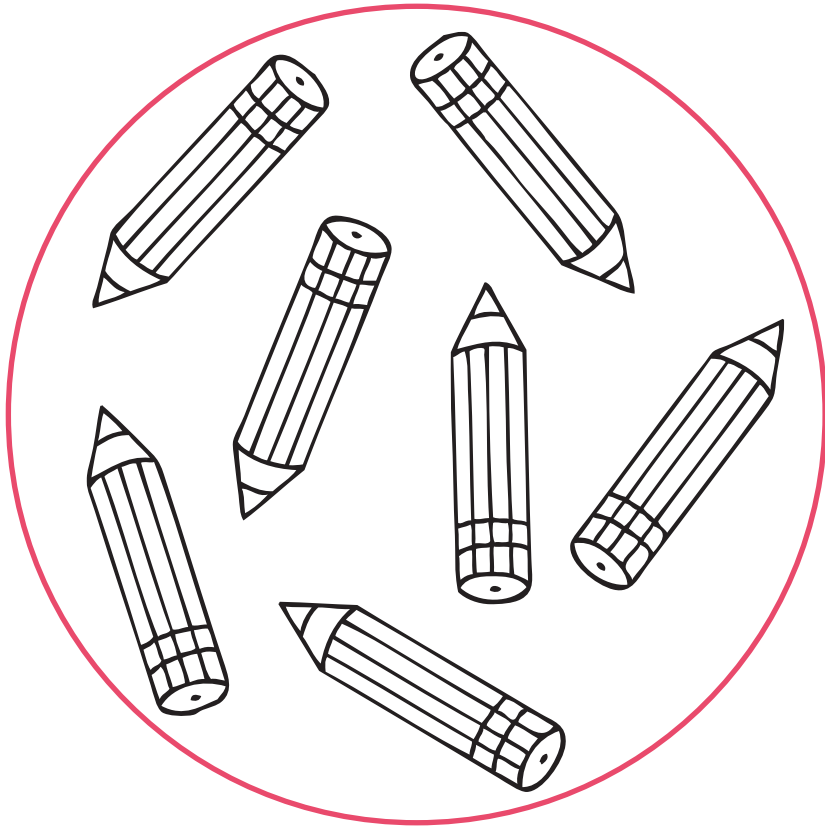

11

10

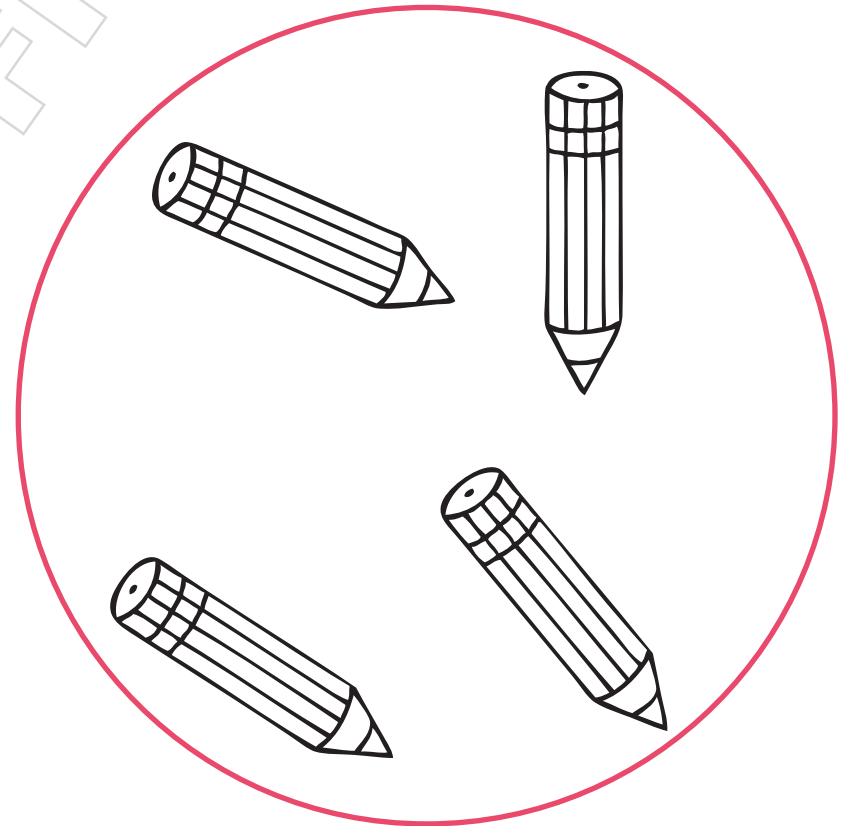

Count the pencils and circle the correct number. Point to the circle with a few pencils and color these yellow. Point to the circle with many pencils and color these blue.

Key Language Review: few, many, pencil, blue, yellow, 10–11

Action Song

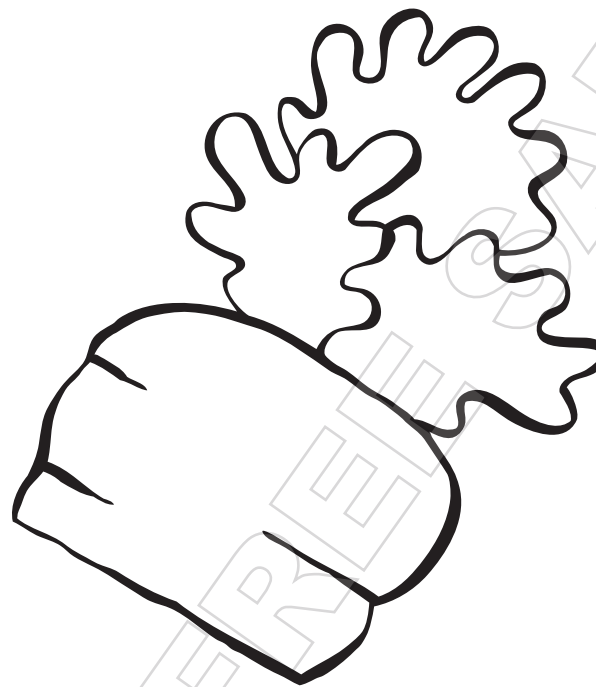

Draw a triangle to complete the carrot. Paint it orange. Point and say the food.

Key Language Review: draw, paint, carrot, triangle, orange



Lesson 8

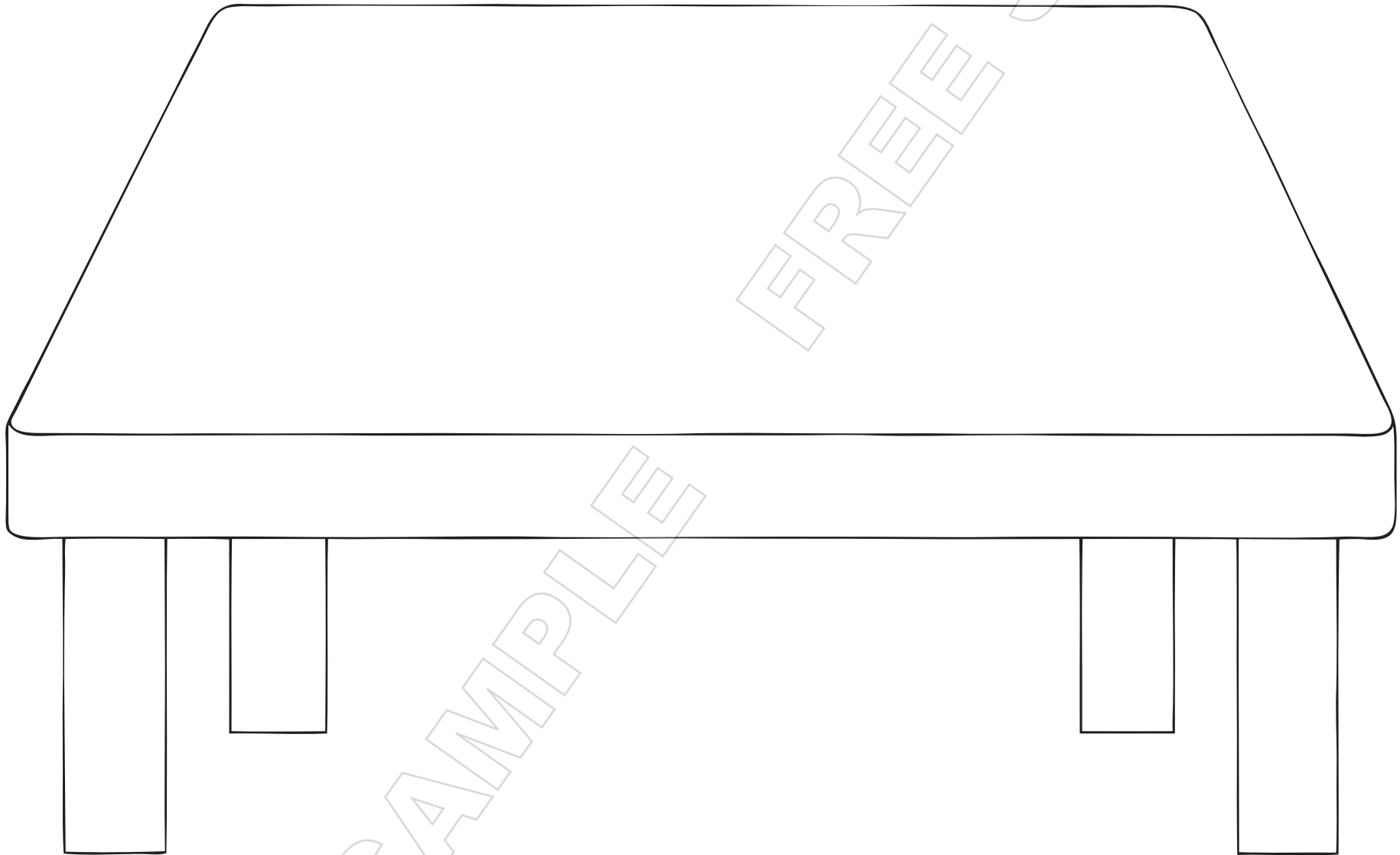

Paste school objects on the table. Point and say: *Where's the (pencil)? It's on the table.*

Key Language Review: school objects, *Where's the (pencil)? It's on the table.*



Complete the Unit 1 Family Time



This is Me!

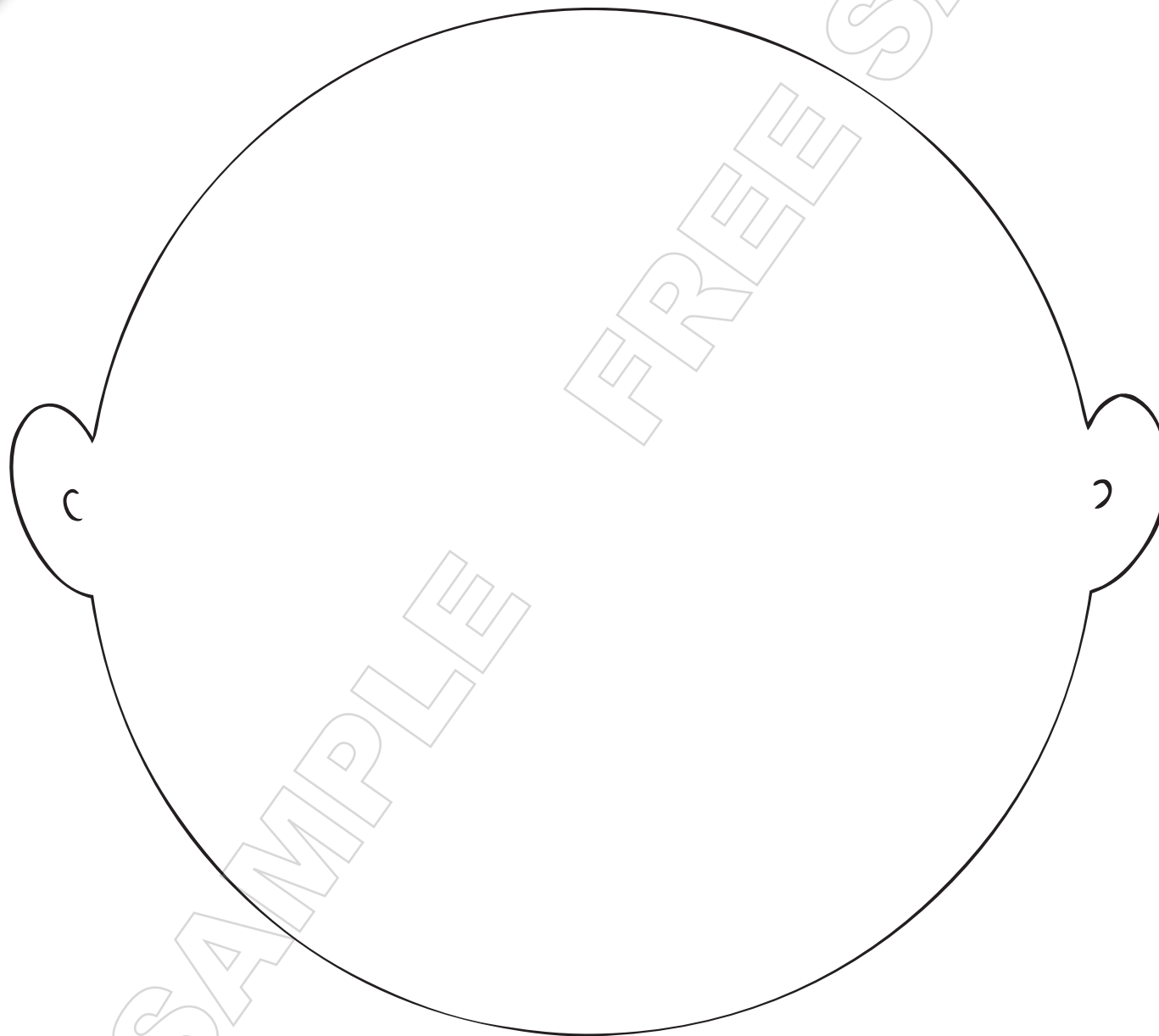

Paste pictures to make your face. Point and say the parts of the face.
Key Language Review: cheeks, ears, eyes, hair, head, mouth, nose, teeth



Lesson 2

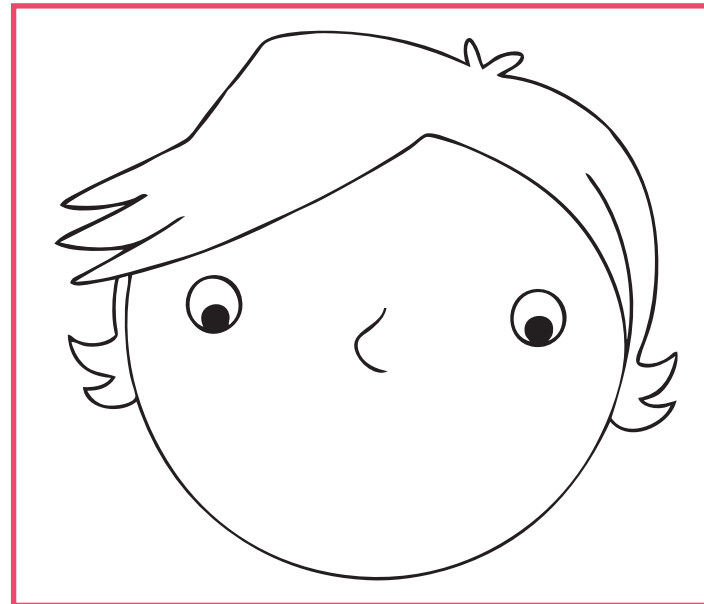
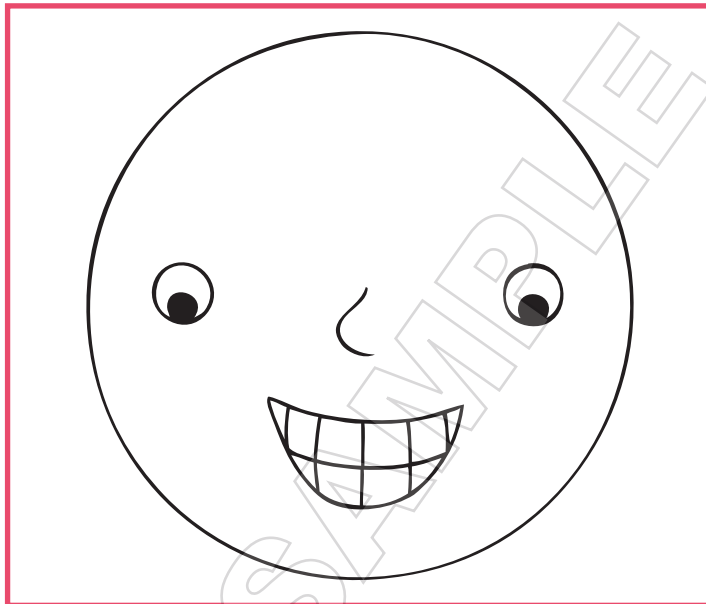
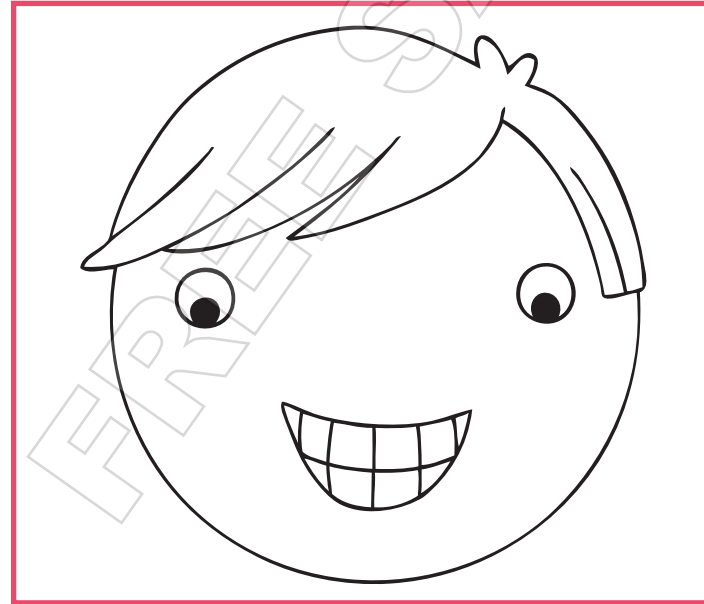
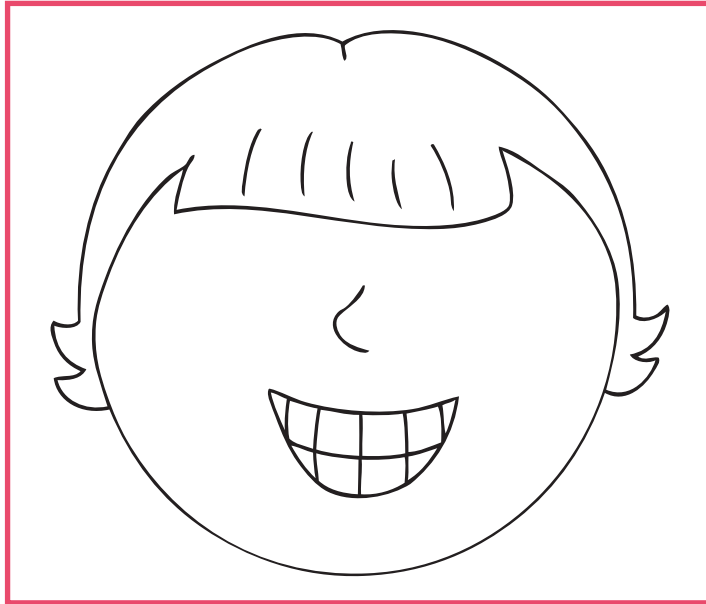

Complete the faces. Point and say: *These are my (eyes). / This is my (nose).*
Key Language Review: eyes, hair, mouth, nose, teeth, These are my (eyes). / This is my (nose).

Storysong

Lesson 3

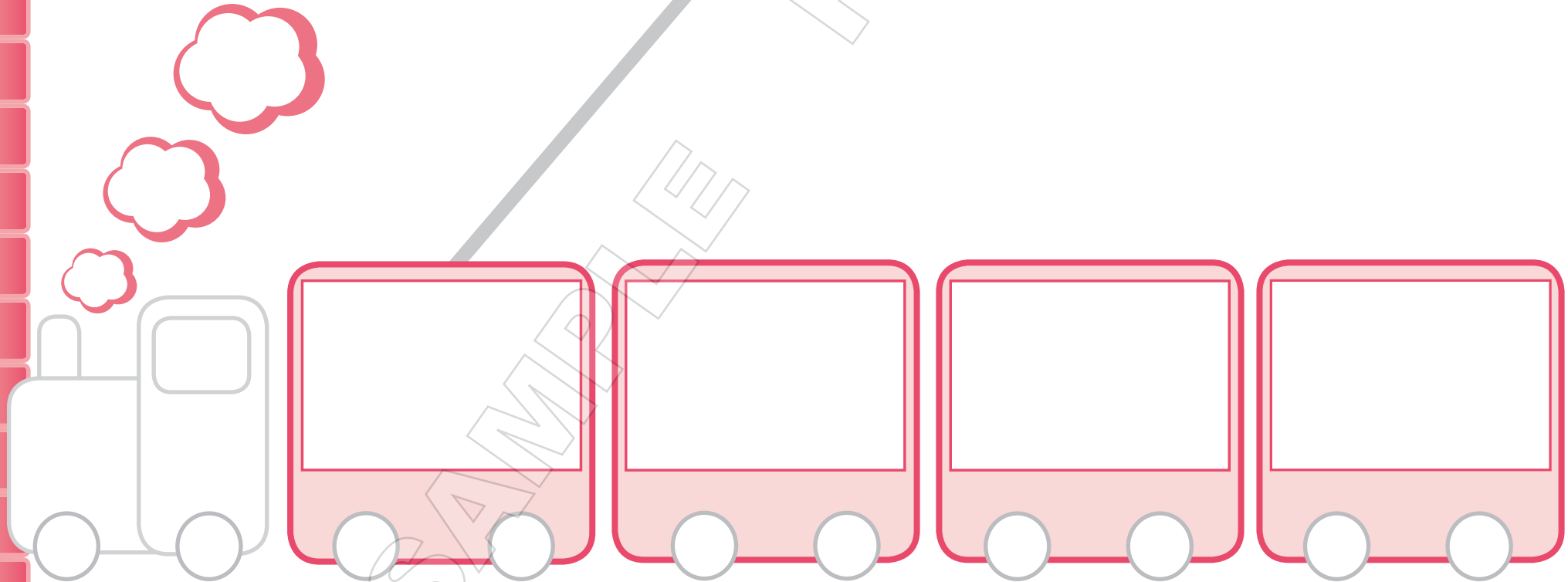
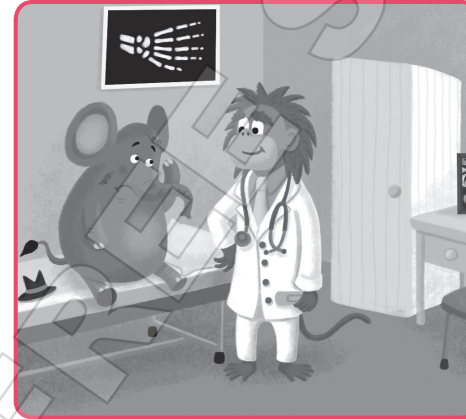
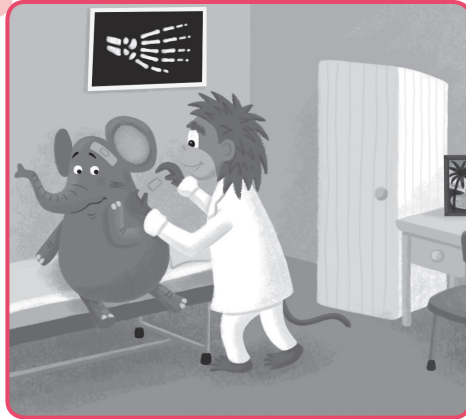

Connect the pictures to the train to complete the story. Paste circles on the wheels in a two blue / two yellow pattern.
Key Language Review: circle, blue, yellow

Lesson 4



10

11

12

Find and circle the differences. Count the differences. Circle the correct number.
Key Language Review: 1–12



Lesson 5



Draw around your hands. Point and say: *What are these? These are my (fingers).*
Key Language Review: fingers, hands, What are these? These are my (fingers).



Lesson 6

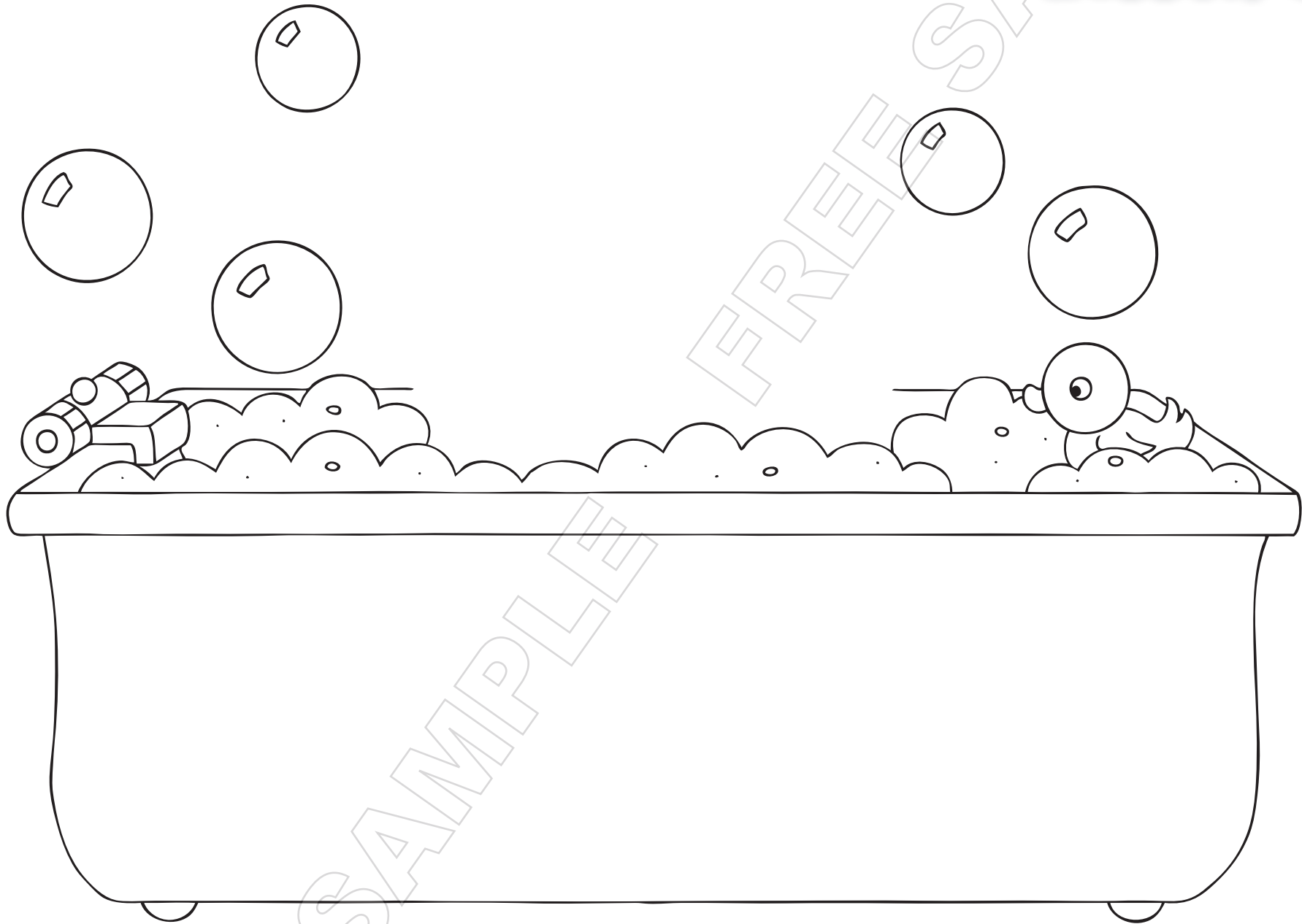

Draw yourself taking a bath. Paste blue paper balls on the big circles. Point and say: *This is my (hair).* / *These are my (arms).*
Key Language Review: bath, parts of the body, circle, blue, *This is my (hair).* / *These are my (arms).*

Action Song

Lesson 7

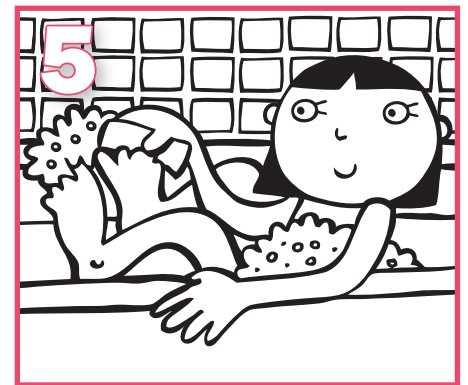
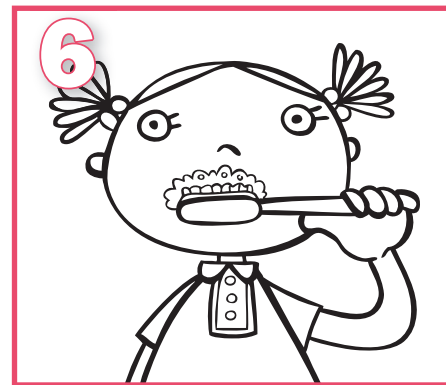
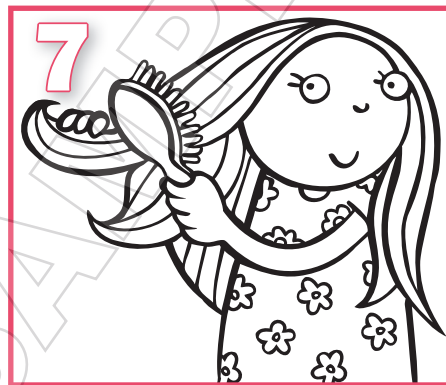
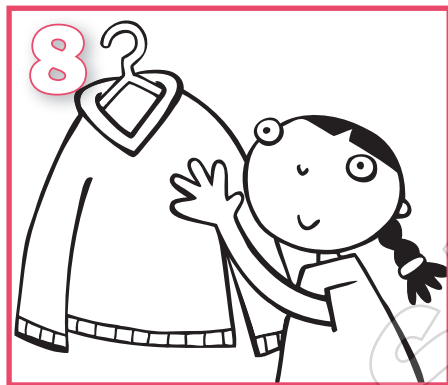
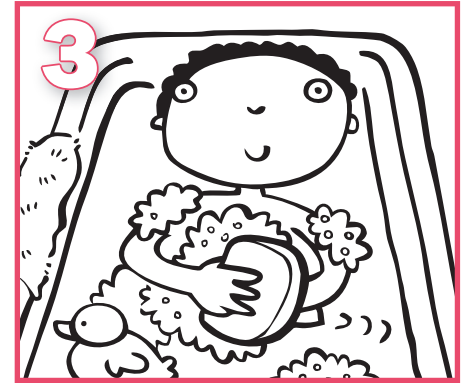
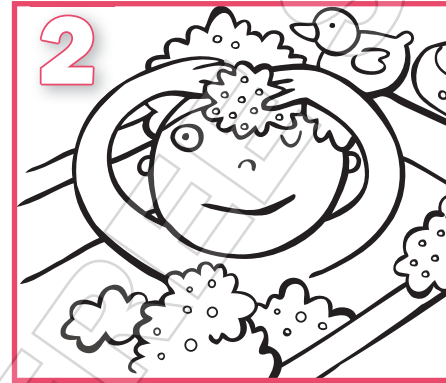
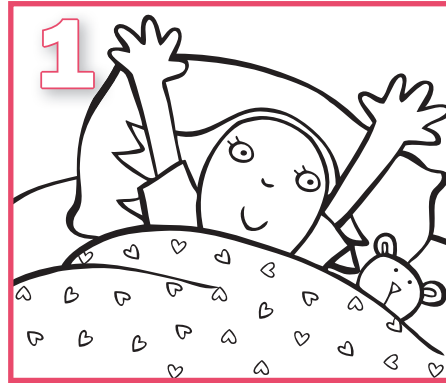
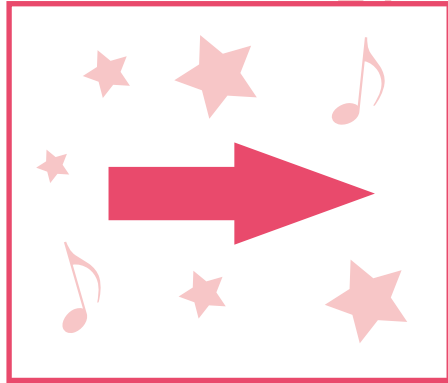

Point and say the parts of the body. Play the "When I Get Up" game. Do the actions.
Key Language Review: brush, pick out, wake up, wash, wriggle, arms, cheeks, hair, knees, teeth, toes



Lesson 8

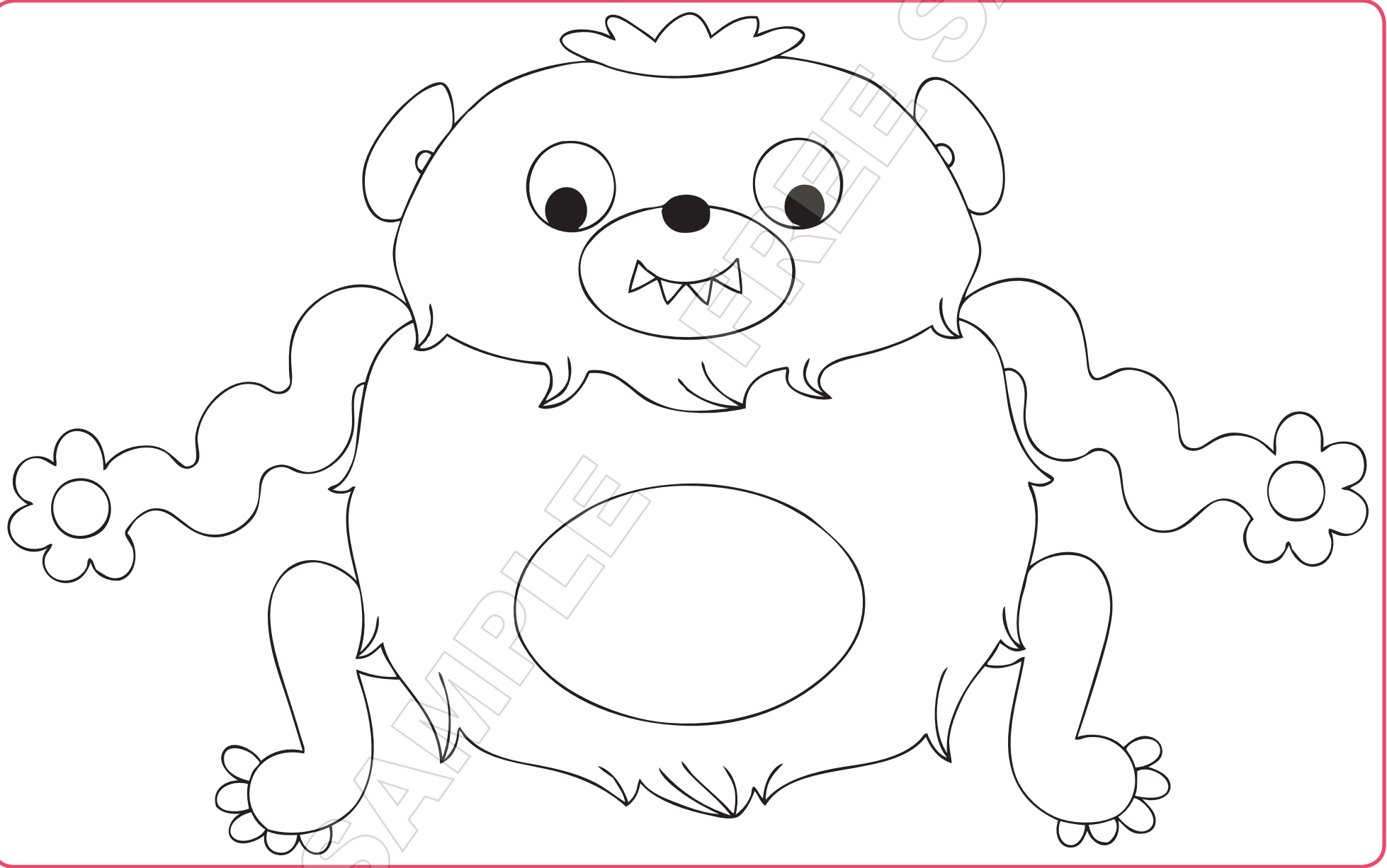

Point and say the parts of the body. Decorate the monster's body.  **Complete the Unit 2 Family Time Activities with your parents.**
Key Language Review: arms, ears, eyes, feet, fingers, hair, hands, head, knees, legs, mouth, nose, shoulders, teeth, toes